

Technical information

Monitor arms

Monitor arm 2000

Max load: 21 kg

Cat. no: 18540 (wall)
18541 (ceiling)
18542 (2x ceiling)

H = Height adapted to the ceiling height.

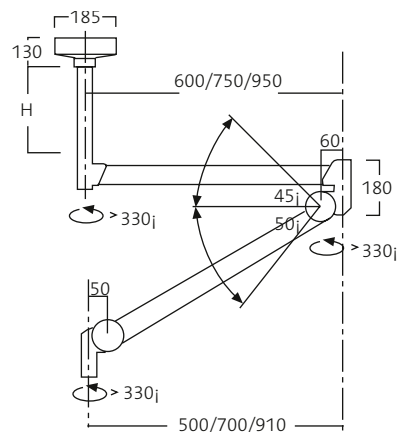

Wall bracket

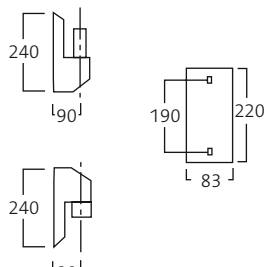

Ceiling bracket for concrete ceilings

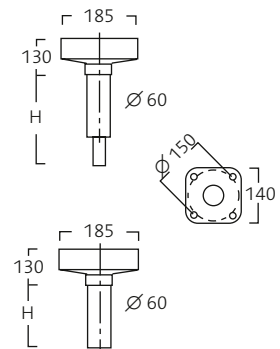

Ceiling bracket for suspended ceilings

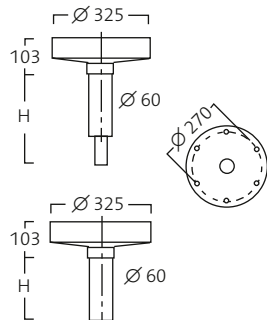

Ceiling bracket double arm

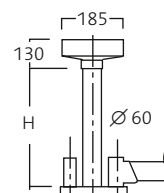

Monitor arm 3000

Max load: 30 kg

Cat. no: 18543 (wall)
18544 (ceiling)

Wall bracket

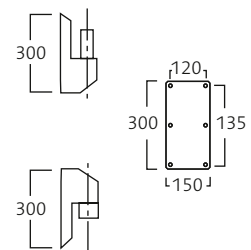

Ceiling bracket

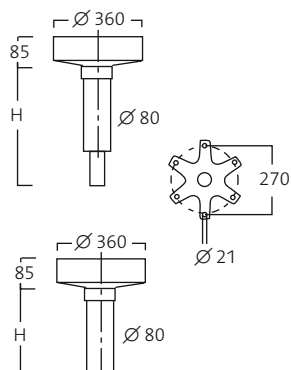

Arms

H = Height adapted to the ceiling height.
E = Electrical 3- or 5-way rotating transfer.

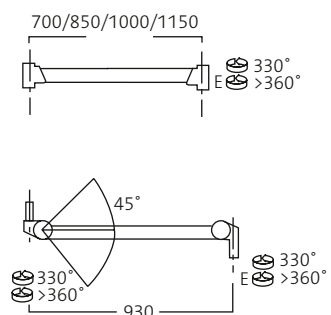

Technical information

Monitor arms

Monitor arm OndaSpace

Max load: 40 kg

Cat no: 18545 (wall)

18546 (ceiling)

Wall bracket

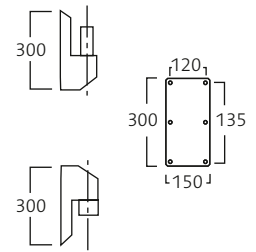

Ceiling bracket

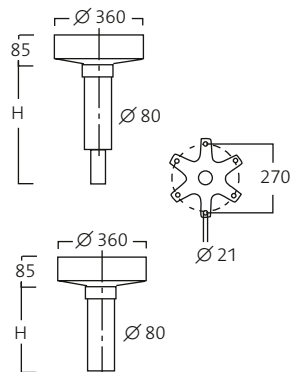

Arms

H = Height adapted to the ceiling height.
E = Electrical 3 or 5-way rotating transfer.

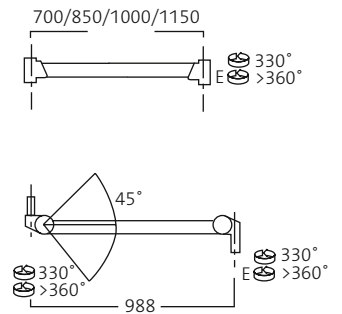

Accessories monitor arm 2000, 3000 and OndaSpace

- 4 kg VarioView 1 × flat screen
- 10 kg VarioView 2 × flat screens
- 10 kg Outlet socket box with shelf
- 7 kg Loop shelf C-Yoke
- 7 kg Loop shelf M-Yoke
- 17 kg Outlet pendant with drip carrier

